

## FOOD FACILITY PLAN REQUIREMENTS



### ENVIRONMENTAL MANAGEMENT DEPARTMENT ENVIRONMENTAL HEALTH DIVISION

11080 White Rock Road, Suite 200  
Rancho Cordova, CA 95670  
(916) 874-6010

[emd-ehplanreview@saccounty.gov](mailto:emd-ehplanreview@saccounty.gov)

[emd.saccounty.gov](http://emd.saccounty.gov)



# Table of Contents

<b>SECTION I: Introduction</b> .....	3
<b>SECTION II: Plan Check Fees</b> .....	3
<b>SECTION III: Plan Submittal</b> .....	3
<b>SECTION IV: General Construction and Equipment Requirements</b> .....	6
A: Floors .....	6
B: Walls and Ceilings .....	7
C: Conduits.....	7
D: Service of Unpackaged Foods Directly to or by the Customer.....	8
E: Storage .....	8
F: Garbage and Trash Storage Area .....	9
G: Restrooms .....	9
H: Locker and Employee Change Rooms .....	10
I: Exterior Doors and Windows .....	10
J: Pass Through Windows .....	10
K: Lighting .....	11
L: Water .....	11
M: Floor Sinks.....	11
N: Sewage Disposal, Grease Traps and Interceptors.....	12
O: Mechanical Exhaust Ventilation .....	13
P: Equipment .....	14
Q: Refrigeration .....	14
R: Ice Machines .....	14
S: Warewashing Sink.....	14
T: Mechanical Warewashing Machines.....	16
U: Food Preparation Sink .....	15
V: Handwashing Sinks .....	15
W: Janitorial Sinks.....	16
X: Dipper Well.....	16
<b>SECTION V: Common reasons for plan rejection</b> .....	16

## **I. INTRODUCTION**

1. This construction guide is available to any person intending to construct or remodel a food establishment within Sacramento County. It is intended to serve as a general overview of the requirements and should not be considered all-inclusive. Recommendations contained in the guide are not requirements in state law or regulation. They are included for clarification and to give examples for meeting the intent of the California Retail Food Code (CalCode). The recommendations may not be applicable in all circumstances. Refer to the California Health and Safety Code, Part 7, Chapter 1, Section 113700 et seq. (CalCode) for specific code requirements. Please contact Environmental Management Department (EMD) if you require further information regarding your particular plan.
2. This guide only encompasses health aspects and should not be construed to encompass requirements of other agencies involved such as, the local planning and zoning department, the local building authority, or local fire department. Owners and agents are advised to contact the appropriate local agencies to obtain any permits and/or to clarify other local codes.
3. For more information concerning this document or to obtain supporting information please go to [emd.saccounty.gov](http://emd.saccounty.gov).
4. The sample drawings in this guideline are not to scale and are not to be copied as approved documents.

## **II. PLAN CHECK FEES - SEE THE ATTACHED PLAN CHECK FEE SCHEDULE**

1. A plan check fee and application form must be submitted at the time of submittal. [Plan Review: Food Facilities, Pools & Spas Fee and Application \(emd.saccounty.gov\)](http://emd.saccounty.gov)
2. A remodel is an alteration to the structure, equipment, or menu of an existing establishment currently under permit.

## **III. PLAN SUBMITTAL**

1. Before constructing or altering any building for use as a food establishment, submit plans to Environmental Health Division (EHD). Plans may be submitted electronically to [emd-ehplanreview@saccounty.gov](mailto:emd-ehplanreview@saccounty.gov) or one hard copy plan can be sent to/dropped off at EMD offices.
2. An architect, draftsman, contractor, or owner may prepare the plans. All plans must be drawn in a concise, detailed and professional manner using 1/4in per foot scale. Inadequate plans will not be accepted. All plans must be accompanied by a plan review application, plan submittal checklist, manufacture spec sheets for equipment and proposed menu.
3. Plans that are submitted will be reviewed within twenty working days and either approved with conditions or disapproved.
  - a) If the plans can be approved after our first review, you will be notified of the next steps.
  - b) If the initial review shows that additional information is required or changes must be made, you will be sent a detailed notice that outlines the needed information or required corrections. **It is your responsibility to gather that information or make the required corrections to the drawings.** Once completed, you may re-submit requested information using the same method as original submittal.
4. One copy of the approved drawings will be kept on file with this department until construction has been completed. An additional copy of the approved drawings must be kept on the job site until final approval.

5. All approved drawings will expire by limitation and may become null and void if the construction, reconstruction, alteration, or other work authorized by the approval is not commenced within one year from the date of approval if no communication has been made with EMD.
6. Any changes to the approved drawings will require that revised drawings be submitted for review and approval before construction.
7. All construction and equipment installation shall be subject to field inspection. The food facility shall not open for business until final approval is obtained from the EHD, Plan Review and a valid Environmental Health permit is issued.
8. Plans shall be drawn to a recommended scale of ¼ inch = 1 foot and shall include:
  - a) Identification showing name and address of establishment.
  - b) A site plan showing trash enclosure areas and parking.
  - c) A floor plan of the entire facility with rooms labeled for usage and door schedule information (self-closures, type).
  - d) A floor plan showing equipment layout. Equipment on the layout drawing shall be numbered to coincide with the numbers on the required equipment schedule. See sample below:

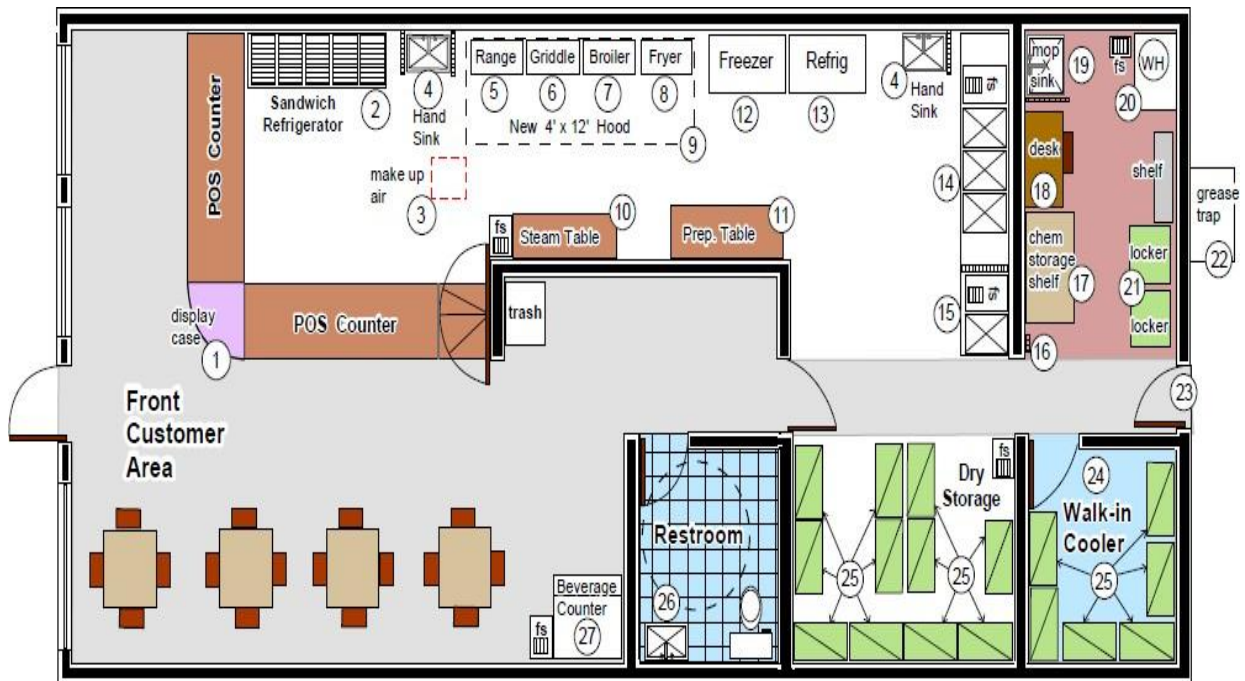

e) An equipment schedule showing make and model number. See sample below that corresponds to sample drawing from item d above.

ITEM NO.	DESCRIPTION	BASE	MANUFACTURER & MODEL ###	WATER HOT COLD	WASTE	REMARKS
1	DISPLAY CASE	ON CASTERS	DISPCS #45B	N/A	SELF-CONTAINED	CONDENSATE EVAPORATOR
2	SANDWICH REFRIGERATOR	CASTERS	LETTOM INC #VBV2	N/A	SELF-CONTAINED	CONDENSATE EVAPORATOR
3	MAKE-UP AIR	ON ROOF				
4	HAND WASH SINK	WALL MOUNTED	WASH CO #XYZ	½" ½"	DIRECT	SOAP & PAPER TOWELS
5	RANGE	6" LEGS	WOODCO #2B	N/A	N/A	
6	GRIDDLE	6" LEGS	COOKUP #3XB	N/A	N/A	
7	BROILER	6" LEGS	BROILCO #B35	N/A	N/A	
8	FRYER	CASTERS	KRISPYCO #582L	N/A	N/A	
9	HOOD		FIREFLY #BUZZ	N/A	N/A	GREASE FILTERS
10	STEAM TABLE	6" LEGS	HOTFDCO #259B	N/A	FLOOR SINK	
11	PREPARATION TABLE	6" LEGS	AMERICAN STEEL #72	N/A	N/A	
12	FREEZER	CASTERS	ICE-KOLD #FZ94	N/A	SELF-CONTAINED	CONDENSATE EVAPORATOR
13	REFRIGERATOR	CASTERS	ICE-KOLD #RF94	N/A	SELF-CONTAINED	CONDENSATE EVAPORATOR
14	WAREWASHING SINK	20" LEGS	BUM EQUIP. #3-18-LR	½" ½"	FLOOR SINK	DUAL DRAINBOARDS
15	FOOD PREP SINK	20" LEGS	BUM EQUIP. #1-18-R	½" ½"	FLOOR SINK	DRAINBOARD
16	MOP/BROOM RACK	WALL MOUNTED				
17	CHEMICAL STORAGE SHELF	72" POSTS	SHELF CO. INC	N/A	N/A	
18	DESK	30" LEGS				
19	MOP SINK	20" LEGS	BUM EQUIP. #1-UTILXB	½" ½"	DIRECT	WITH VACUUM BREAKER
20	WATER HEATER	6" STAND	HTWTR-50B		FLOOR SINK	40,000 BTU'S
21	EMPLOYEE LOCKERS	6" LEGS		N/A	N/A	6 LOCKERS
22	GREASE TRAP	UNDERGROUND	GRTP-500ZC	N/A	DIRECT	OUTSIDE
23	AIR CURTAIN	ABOVE REAR DOOR	NOFLY CO #55GH	N/A	N/A	
24	STORAGE SHELVING	72" POSTS	SHELF CO. INC.	N/A	N/A	
25	WALK-IN COOLER	FLOOR MOUNTED	ICE-KOLD #WKIN58	N/A	FLOOR SINK	
26	HAND WASH SINK	WALL MOUNTED	PORCWSH #45XP	½" ½"	DIRECT	SOAP & PAPER TOWELS
27	SODA MACHINE	ON BEVERAGE COUNTER	BEVERGEUP #6BC	½"	FLOOR SINK	FOR CUSTOMER SELF-SERVICE

- f) Manufacturer's specification sheets that are numbered to coincide with the equipment schedule.
- g) A separate floor plan showing plumbing (hot and cold water diagrams, waste line diagrams and water heater size, type and location)
- h) A separate floor plan showing electrical details including lighting (remodel plans shall identify all existing structures, spaces, and equipment).
- i) A finish schedule for walls, ceiling, cove base and floors indicating the type of material, surface finish for each room. Samples of the proposed finish materials may be required.
- k) Mechanical exhaust floor plan showing HVAC register locations.
- l) Manufacture hood drawings (UL listed hoods) or hood & duct dimensions (unlisted/custom hoods) as well as an air balance schedule.

#### IV. GENERAL CONSTRUCTION AND EQUIPMENT REQUIREMENTS

The plans shall show and specify, in detail, the following:

##### 1. FLOORS (CalCode 114268)

- a) Floors in food establishments (except in sales and dining areas) shall be durable, smooth, nonabsorbent and easily cleanable. Floor surfaces in all areas where food is prepared, packaged, or stored, where any utensil is washed, where refuse or garbage is stored, where janitorial facilities are located, in all toilets and hand washing areas, shall be an approved type. Refer to Approval Floor Materials handout for details. [Flooring Materials for Retail Food Facilities \(emd.saccounty.gov\)](http://emd.saccounty.gov).
- b) Floor surfaces shall be coved at the juncture of the floor and wall with a 3/8 inch minimum radius coving and shall extend up the wall and toe-kicks of floor-mounted counters/cabinets at least 4 inches, except in areas where food is stored only in unopened bottles, cans, cartons, sacks, or other original shipping containers.

##### Correct top set installation:

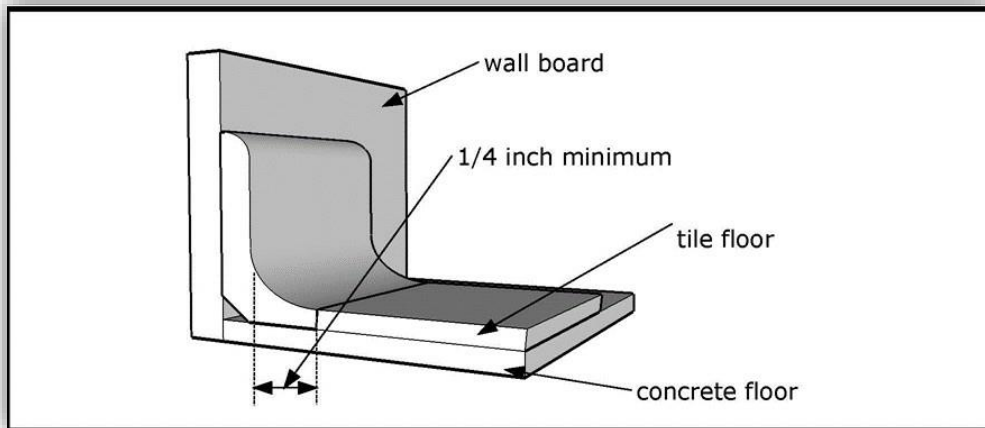

##### Incorrect top set installation:

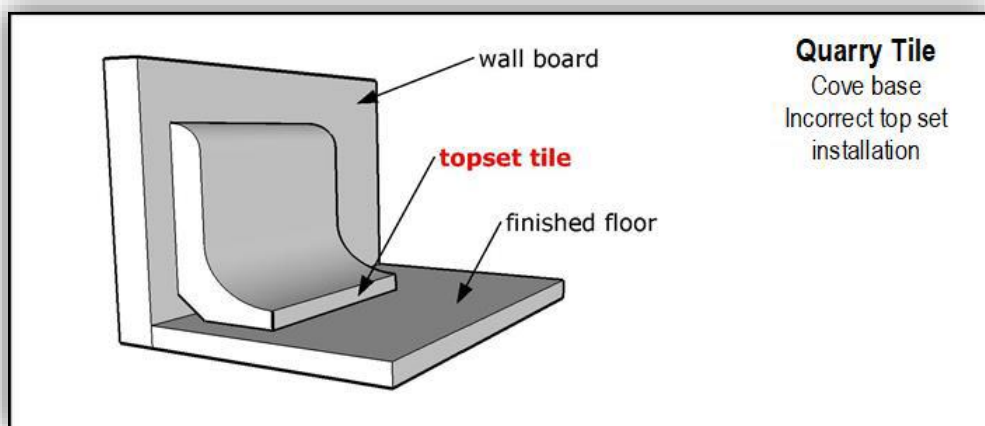

- c) Upon new construction or extensive remodeling, floor drains shall be installed in floors that are water-flushed for cleaning and in areas where pressure spray methods for cleaning equipment are used. Floor surfaces in areas pursuant to this subdivision shall be sloped to the floor drains.
- d) Samples or specification sheets for finishes that are known to vary with regards to thickness and texture, such as epoxy, sheet vinyl, and porcelain tiles may be required.

**2. WALLS AND CEILINGS (CalCode 114271)**

- a) Walls and ceilings of all rooms, (except bars, dining areas, and rooms where food is stored in unopened bottles, cans, cartons, sacks, or other original shipping containers), shall be of a durable, smooth, nonabsorbent, and easily cleanable surface.
- b) All walls and ceilings shall be smooth, with texture no more than orange peel and easily cleanable; e.g. painted gypsum board, FRP, metal or tile. Paint used on gypsum board or similar surfaces shall be gloss or semi-gloss or equivalent.
- c) Overhead pipes, conduits, ducts, beams, and other structures must be concealed above the finished ceiling.
- d) No exposed sewer lines shall be installed above food or beverage areas.
- e) The inside and outside of the casework and cabinetry must be smooth and easily cleanable.
- f) Samples or specification sheets for finishes may be required.

**3. CONDUITS (CalCode 114271)**

- a) All plumbing, electrical, and gas lines shall be concealed within the building walls, floors and ceiling or within approved conduit runs or chases. Do not install conduit or pipelines across any aisle, traffic area or door opening.
- b) Where conduit or pipelines enter a wall, ceiling or floor, the opening around the line(s) shall be tightly sealed.

**4. SERVICE OF UNPACKAGED FOODS DIRECTLY TO OR BY THE CUSTOMER (Refer to CCDEH Buffet Service Guidelines 2008)**

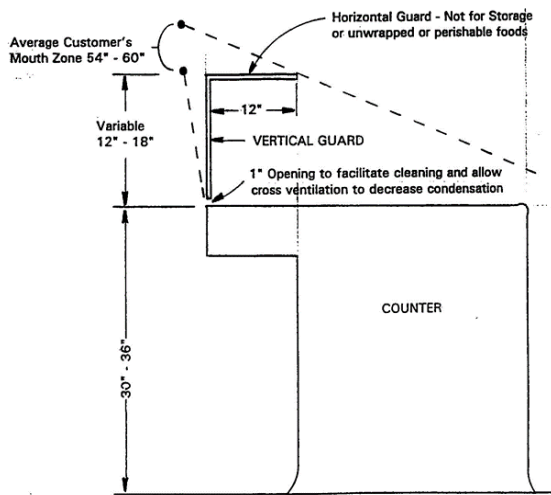

a) With the exception of produce displays in retail grocery stores, unpackaged foods shall be shielded so as to intercept a direct line between the customer's mouth and the food being displayed, or shall be dispensed from approved self-service containers. Provide detailed drawings (scale 1 inch = 1 ft.) of all proposed sneeze guards, including a detail showing the 54"-60" nose/mouth zone to the top of the display. See adjacent sample drawing.

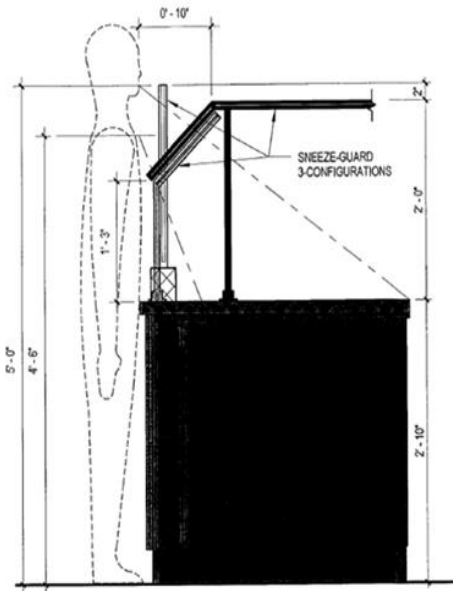

b) Utensils, food preparation surfaces, and food preparation equipment which are located adjacent to customer accessible areas, must be protected by approved sneeze guards. See adjacent sample drawing.

**5. STORAGE (CalCode Section 114047)**

- a) Adequate and suitable floor space and shelving shall be provided for the storage of food, beverages, and all food related products.
- b) The quantity of dry storage shall be no less than 144 square feet for restaurants and no less than 72 square feet for bars or similar operations. Additional dry storage may be required based on menu and size of facility.
- c) Each department in a market which handles unpackaged foods, e.g., deli, meat, fish, bakery etc., and additional operations in restaurants, e.g., sushi bars, oyster bars, etc., must have additional, designated dry storage.



- d) Working storage (wall mounted shelves or cabinets over and under food handling equipment which are located in and used in conjunction with food preparation areas) shall not be used in calculating dry food, back up storage.
- e) All shelving shall be durable, smooth, and easily cleanable. Shelving units must be ANSI certified, NSF or equivalent. Raw wood shelving is not approved. The lowest shelf shall be at least six (6) inches above the floor, with a clear, unobstructed area below.
- f) Food and food related products may not be stored in attics, unfinished basements or areas that are difficult to access, and should not be stored in remote areas outside of the facility (e.g. unapproved trailers, cargo containers, sheds, etc.).
- g) A room, area or cabinet separated from any food preparation or storage area, or utensil washing or storage area, must be provided for the storage of all cleaning equipment, supplies and poisonous substances (e.g., mops, buckets, brooms, cleaning compounds, detergents or any other injurious or poisonous materials).  
[CalCode 114254 & 114254.2]

**6. GARBAGE AND TRASH STORAGE AREA (CalCode 114244 and 114245)**

- a) An area shall be provided for the storage of garbage and trash containers.
- b) If located within the food facility, a storage area for refuse, recyclables, and returnables shall meet the requirements for floors, walls, ceilings, and vermin exclusion. The room shall be well ventilated.
- c) If provided, an outdoor storage area or enclosure used for refuse, recyclables, and returnables shall be constructed of nonabsorbent material such as concrete or asphalt and shall be easily cleanable, durable, and sloped to drain. Outdoor trash storage areas should not be in close proximity to delivery doors.

**7. RESTROOMS (CalCode Section 114250 and 114276, Sacramento County Code 6.04.090 and 6.04.095)**

- a) Toilet facilities shall be provided within each food establishment, convenient for the employee and within 200 feet of the facility's main entrance. The number of toilet facilities shall be in accordance with the local building and plumbing codes.
- b) Food facilities located with amusement parks, stadiums, arenas, food courts, fairgrounds, and similar premises shall not be required to provide toilet facilities for employee use within each food facility if approved toilet facilities are located within 200 feet in travel distance of each food facility and are readily available for use by employees.
- c) Toilet facilities shall be so situated that patrons do not pass through food preparation, food storage, or utensil washing areas when they are allowed access to the toilet facilities.
- d) The floors, walls, and ceilings shall have surfaces that are durable, smooth (non-textured), nonabsorbent, and easily cleanable.
- e) Handwashing facilities shall be provided within or immediately adjacent to the toilet rooms. The handwashing facility shall be provided with hot and cold running water from a mixing type faucet. Handwashing soap and single-use towels shall be provided in enclosed dispensers installed adjacent to each handwashing facility. Heated-air hand drying devices may be installed in lieu of single-use towels.

- f) Toilet tissue shall be provided in a permanently installed dispenser at each toilet.
- g) The restrooms shall be provided with self-closing, tight fitting doors.
- h) Toilet rooms shall be vented to the outside air by means of an openable, screened window or a light-switch-activated exhaust fan, consistent with the requirements of local building codes.

**8. LOCKERS AND EMPLOYEE CHANGE ROOMS: (CalCode 114256)**

- a) Lockers or other suitable facilities shall be provided for employee clothing and other possessions.
- b) Lockers or other suitable facilities shall be located in a designated room or area where contamination of food, equipment, utensils, linens, and single-use articles cannot occur. Areas where employees eat and drink shall be located so that food, equipment, linens, and single-use articles are protected from contamination.

**9. EXTERIOR DOORS AND WINDOWS: (CalCode Section 114259)**

- a) Each permanent food facility shall be fully enclosed in a building consisting of permanent floors, walls, and an overhead structure that meet the minimum standards. All exterior doors shall be well fitted and self-closing to effectively prevent the entrance of flies, rodents, and vermin.
- b) Bi-folding doors and windows, roll-up doors, Nana Wall Systems or similar openings located between the building exterior and dining areas are only permitted when all food and beverage handling/storage areas are fully enclosed. Alcohol bars may be located in an open dining area, provided that no food preparation occurs within the bar and ice bins are maintained with lids between uses.
- c) All openable windows, such as restroom windows, shall be screened with not less than 16 per square inch mesh screening.
- d) All exterior roll-up doors that open directly into a food and/or utensil handling area shall be equipped with an approved air curtain to operate automatically when the door is opened. The air curtain(s) must be at least the same width as the door opening. Dock seals may be provided in lieu of an air curtain in warehouse areas.

**10. PASS THROUGH WINDOWS: (CalCode 114259.2)**

- a) Pass-through window service openings shall be limited to 216 square inches each without an air curtain or 432 square inches with an air curtain. Multiple window openings shall not be closer together than 18 inches. Each opening shall be provided with a solid or screened window, equipped with a self-closing device. Screening shall be at least 16 mesh per square inch.
- b) Air curtains at pass-through windows must operate automatically whenever the window is opened.

11. **LIGHTING (CalCode)Á**

- a) Light fixtures in areas where food is prepared, where open food is stored, or where utensils are cleaned shall be of shatterproof construction or protected with shatterproof shields and shall be easily cleanable.
- b) Dishwashing areas, server stations where food is prepared, toilet rooms and bars shall be provided with at least 20 foot-candles of light, as measured 30 inches above the floor.
- c) Food and utensil storage rooms, refrigerated storage areas, and dressing rooms shall be provided with at least 10 foot-candles of light.
- d) Where food is prepared, at least 50-foot candles shall be provided at a surface where a food employee is working with food or working with utensils or equipment such as knives, slicers, ginders, or saws where employiye safety is a factor.

12. **WATER (CalCode 114192)**

æD An adequate, protected, pressurized, potable supply of cold and hot water (120 degrees Fahrenheit) to all sinks, lavatories and other cleanup facilities shall be provided. Indicate the water heater capacity (gallons), BTU's or kW's for tank style units or gallon per minute (gpm) rating at 60F rise for tankless units.

àD The water supply shall be approved by EMD and local building department. If the facility is using water from a well, it must be installed by a licensed well driller and certified by EMD. EMD Well and Septic Program will verify well construction and water quality is in compliance with applicable code.

13. **FLOOR SINKS (CalCode 114193 and CPC 704.3)**

- a) All condensate and similar liquid waste, e.g., espresso machines, soda and beer dispensers, and some coffee units, walk-in refrigerators/freezers, food preparation sinks, steam tables, ice machines, shall be drained by means of indirect waste pipes into a floor sink. Floor sinks shall be installed in compliance with local plumbing ordinances and shall be easily accessible. See sample drawing below.



- b) Warewashing sinks and warewashing machines shall drain to floor sinks unless the local building department requires a direct connection. When plumbed direct, connections to sewer must meet plumbing code requirements. See sample drawing below of Indirect Waste Drainage.



- c) Floor sinks shall be installed flush with the finished floor surface and located within 15 feet of the wastewater producing equipment, or closer depending on the height of the equipment drain outlet. For ice machines, proofers, or baking ovens with drains located in close proximity to the floor, the floor sink should be located immediately adjacent to the equipment.
- d) Drain lines shall slope to floor sinks at a minimum of  $\frac{1}{4}$  inch per foot. There must be a minimum one inch air gap between the drainpipe opening and the flood rim of the floor sink.
- e) Floor sinks must be located to be easily visible for inspection and easily accessible for cleaning.

#### 14. SEWAGE DISPOSAL, GREASE TRAPS AND INTERCEPTORS (CalCode 114201)

- a) All liquid waste, including "gray water" and "black water" generated by a food establishment, shall be disposed of through the approved plumbing system and must discharge into a public sewer or into an approved private sewage disposal system. If a septic system is used, it must be approved by the appropriate regulatory authority. Contact EMD for information on how to verify septic system compliance and approval.
- b) The need and size for a grease trap/interceptor is determined by the local public sewer authority department. However, if provided, a grease trap/interceptor shall NOT be located in a food or utensils handling area unless specifically approved by EMD.
- c) Each grease removal device must be readily accessible for servicing.

## 15. MECHANICAL EXHAUST VENTILATION (CalCode 114149)

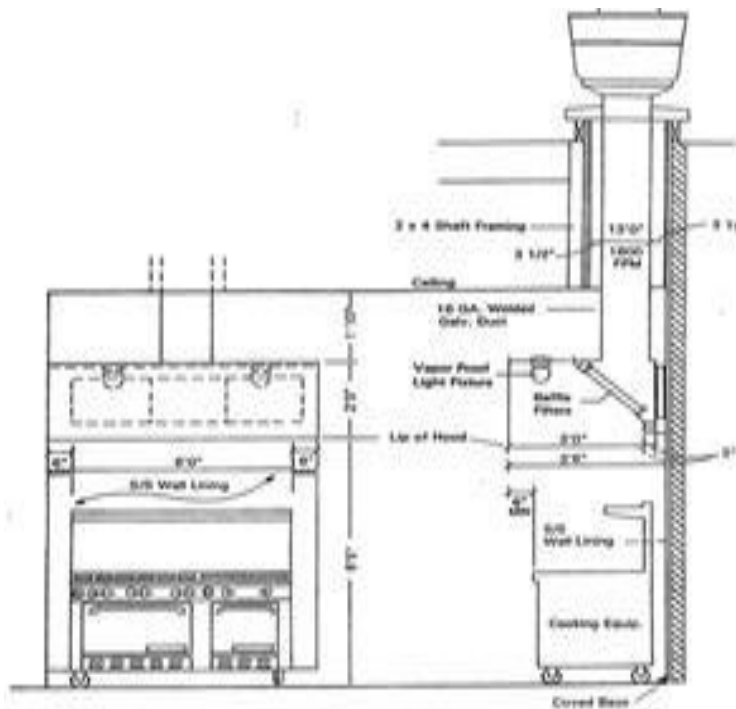

a) Mechanical exhaust ventilation equipment shall be provided over all cooking equipment as required to effectively remove cooking odors, smoke, steam, grease, heat, and vapors. All mechanical exhaust ventilation equipment shall be installed and maintained in accordance with the California Mechanical Code.

b) All areas of a food facility shall have sufficient ventilation to facilitate proper food storage and to provide a reasonable condition of comfort for each employee, consistent with the job performed by the employee.

### c) EXHAUST HOODS AND DUCTS

1. A Type-I exhaust hood shall be required over all cooking equipment that may produce grease-laden vapors, such as ranges, griddles, deep fat fryers, charbroilers, wok ranges, tandoor ovens, rotisseries, tilting-skillets, etc.
2. A Type-II exhaust hood shall be required over all equipment that may produce steam, heat and non-grease-laden vapors, such as upright mechanical dishwashers, gas-fired appliances including gas rice cookers, gas steam tables, ovens that do not require Type-I hoods, re-thermalizers, gas-fired coffee roasters, steamers, etc.
3. In addition to mechanical drawings, provide the manufacturer's hood drawings including overhead details, duct size, exhaust fan schedule, and calculations.
4. Provide an air balance schedule that indicates all exhaust, make-up air, and any outside air to be supplied by the HVAC system. Doors, windows, or louvers may not be used as make-up air. 100% make-up design is required and electrically interconnected with exhaust system.

### ci) Hood Exemptions

1. Certain types of cooking equipment (e.g., induction cookers, convection ovens, hot plates) may be considered for exemption from exhaust hood requirements. Contact EMD Plan Review for additional information on exhaust hood exemptions.

## 16. EQUIPMENT (CalCode 114130, 114169)

- a) All new and used equipment and utensils shall be certified or classified for sanitation by an American National Standards Institute (ANSI) accredited certification program, e.g. NSF, ETL Sanitation, UL EPH, UL Sanitation, CSA Sanitation. Equipment design, construction and installation are subject to approval by the enforcement agency.



- b) All cracks and crevices at construction joints of counters, cabinets, bars, and similar fixtures shall be sealed with a caulking type of sealant. All finishes shall be smooth and washable.
- c) All equipment shall be installed on casters, six (6) inch high round metal legs, or on a minimum four (4) inch high curb or pedestal with a continuously covered base at the floor juncture.
- d) Equipment that is fixed because it is not easily movable shall be spaced to allow access for cleaning along the sides, behind, and above the equipment, or shall be sealed to adjoining equipment or walls.
- e) Walk-in coolers and freezers, exhaust hoods, and some large bakery equipment must be flashed to the ceiling with an approved washable material to close off an area that is otherwise not easily accessible for cleaning.

## 17. REFRIGERATION (CalCode 114153, 114157, 114193, CPC)

- a) All refrigeration units shall be adequate in capacity for the needs of the proposed operation and shall comply with the following requirements:
1. Be certified or classified for sanitation by an American National Standards Institute (ANSI) accredited certification program.
  2. Capable of maintaining food temperatures below 41° Fahrenheit and provided with an accurate, readily visible thermometer.
  3. Have condensate waste drain into a floor sink via a legal airgap, or into an approved integral evaporator unit.
  4. Have shelving that is at least six (6) inches off the floor with smooth, round metal legs and plastic-coated to prevent rust damage.
- b) Floor sinks and floor drains should not be located inside of the walk-in refrigeration units or freezers.

## 18. ICE MACHINES (CalCode 114193)

- a) All ice machines shall be located within the building in an easily cleanable, well-ventilated area and shall drain to a floor sink.

**19. WAREWASHING SINK (CalCode Chapter 5: Cleaning and Sanitizing of Equipment)**

- a) Where multiservice kitchen utensils (i.e., pots, pans, spatulas, tongs, knives, scoops, etc.) and equipment are utilized or where food is prepared, a three-compartment approved stainless steel sink with two integral installed stainless steel drainboards must be provided. A mechanical warewashing machine shall not substitute for a three-compartment sink.
- b) The sink must be capable of accommodating the largest utensil to be washed and the drainboards shall be as large as the largest sink compartment. [CalCode 114099].
- c) Bars and separate food or beverage facilities located within restaurants may be required to have either a three-compartment sink or warewashing machine. A three-compartment sink may also be required within each separate section of a large food establishment that handles unpackaged foods (i.e., sushi, deli, meat, bakery or oyster bars, etc.).

**20. MECHANICAL WAREWASHING MACHINES (CalCode Chapter 5: Cleaning and Sanitizing of Equipment)**

- a) Upright mechanical warewashing machines that are heat sanitizing must be installed beneath a type II exhaust hood. Make-up air will be required as part of the overall mechanical exhaust system.
- b) All warewashing equipment shall be provided with two integral stainless steel drainboards of adequate size and construction. One drainboard shall be attached at the point of entry for soiled equipment and utensils and one shall be attached at the point of exit for cleaned and sanitized equipment and utensils.
- c) Each facility shall be equipped with a three-compartment stainless steel sink with two integral stainless steel drainboards even when a mechanical warewashing machine is present.

**21. FOOD PREPARATION SINK (CalCode 114163)**

- a) All food facilities that wash, rinse, soak, thaw, or similarly prepare foods shall be provided with a food preparation sink. The food preparation sink shall have a minimum dimension of 18 inches by 18 inches in length and width and 12 inches in depth with an integral drainboard or adjacent table at least 18 inches by 18 inches in length and width. This sink must be provided with hot and cold running water through a combination faucet and must drain to the sanitary sewer by way of an indirect sanitary sewer connection through a floor sink. Additional food preparation sinks may be recommended depending on operation.

**22. HANDWASHING SINKS (CalCode 113953)**

- a) Handwashing sinks shall be equipped to provide warm water (at least 100°F.) under pressure for a minimum of 15 seconds through a mixing valve or combination faucet. If the temperature of water provided to a handwashing sink is not readily adjustable at the faucet, the temperature of the water shall be at least 100°F, but not greater than 108°F.
- b) A handwashing sink shall be provided in each restroom, food preparation and warewashing area.

- c) The handwashing sink shall be separated from the warewashing sink by a metal splashguard with a height of at least 6 inches that extends from the back edge to the front edge of the drainboard, with corners of the barrier to be rounded. A splash guard is also required between the handwashing sink and food preparation sink, and between the food preparation sink and three-compartment sink that have less than 24 inches between them.
- d) Enclosed handwashing soap and single-use towel dispensers shall be provided adjacent to each handwashing facility.

**23. JANITORIAL SINK (CalCode 114279)**

- a) At least one janitorial sink shall be provided and conveniently located for the cleaning of mops or similar wet floor cleaning tools, and for the disposal of mop water and similar liquid waste. The faucet must be equipped with hot and cold water and a backflow prevention device. The sink shall be located to prevent contamination of food preparation area, food storage areas, utensils or equipment.
- b) Provide a mop hanger positioned so that mops drip into the janitorial sink. After use, mops shall be placed in a position that allows them to air-dry without soiling walls, equipment, or supplies.
- c) A room, area or cabinet, separated from any food preparation or storage area, or washwashing or storage area, shall be provided for the storage of clean equipment and supplies, such as mops, buckets, brooms, cleansers, and waxes.

**24. DIPPER WELL (CalCode 114119)**

- a) If scoops or other reusable serving utensils are used repeatedly for portioning (e.g. ice cream and gelato service), one of the following dipper wells shall be provided:
  - 1) Cold running water dipper well that is ANSI certified. Water shall be of sufficient velocity to flush particulates to drain into a floor sink.
  - 2) Heated dipper well that is ANSI certified to maintained water at 135F degrees or above.

**V. COMMON REASONS FOR PLAN REJECTION**

The following are common problems resulting in rejection of plans and delay in construction:

1. Plans not drawn to scale.
2. Incomplete floor plan.
3. Conflicting information given (e.g., plumbing plan and equipment do not agree).
4. Insufficient detail provided on finish schedule.
5. Menu or list of foods to be prepared not provided.
6. Incomplete equipment layout, including insufficient information on equipment manufacture name, specifications and model number.
7. No floor sinks for equipment requiring indirect drainage.
8. Hand washing facilities inadequate.
9. Ventilation hood specifications inadequate or insufficient information provided.
10. Insufficient water heater details.